



# USB3.0 Fixture Board User's Manual

Preliminary

Model: U3EX

FAE2009U3EX\_01

July 2009

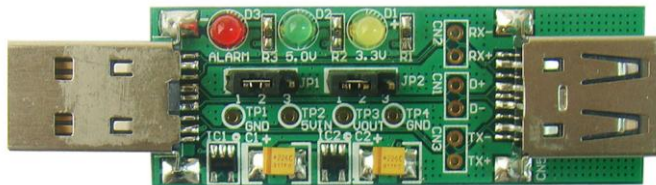

**Bplus Technology Co., Ltd.**  
**5F, No.63, Zhou-Tzyy St., Nei-Hu,**  
**Taipei, Taiwan**  
**(886-2)77210550 TEL**  
**(866-2)87974200 FAX**  
<http://www.Bplus.com.tw>

# CONTENTS

Introduction.....	2
Interface.....	2
Function .....	3
Schematic profile.....	3
Application note.....	4
Caution .....	7
Maintenance .....	7

## 1.0 Introduction

The USB Fixture is a test tool for USB 3.0 interface with multi-functions of voltage switch, voltage test and current test.

It's especially designed to save valuable labor and time in the production environment.

The USB Fixture is constructed of high quality components for years of trouble free service.

## 2.0 Interface

USB 3.0 Fixture Board as shown,

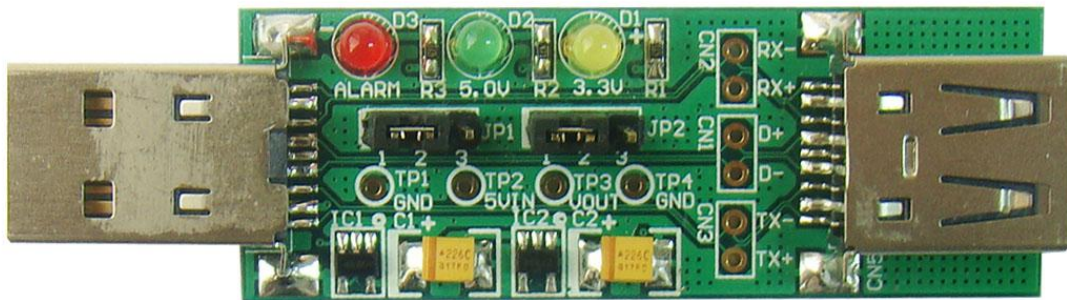

Figure-1 USB3.0 Fixture Board (heads)

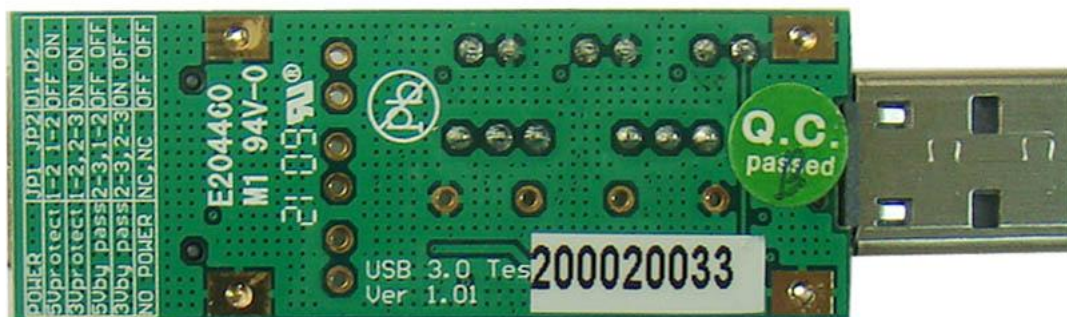
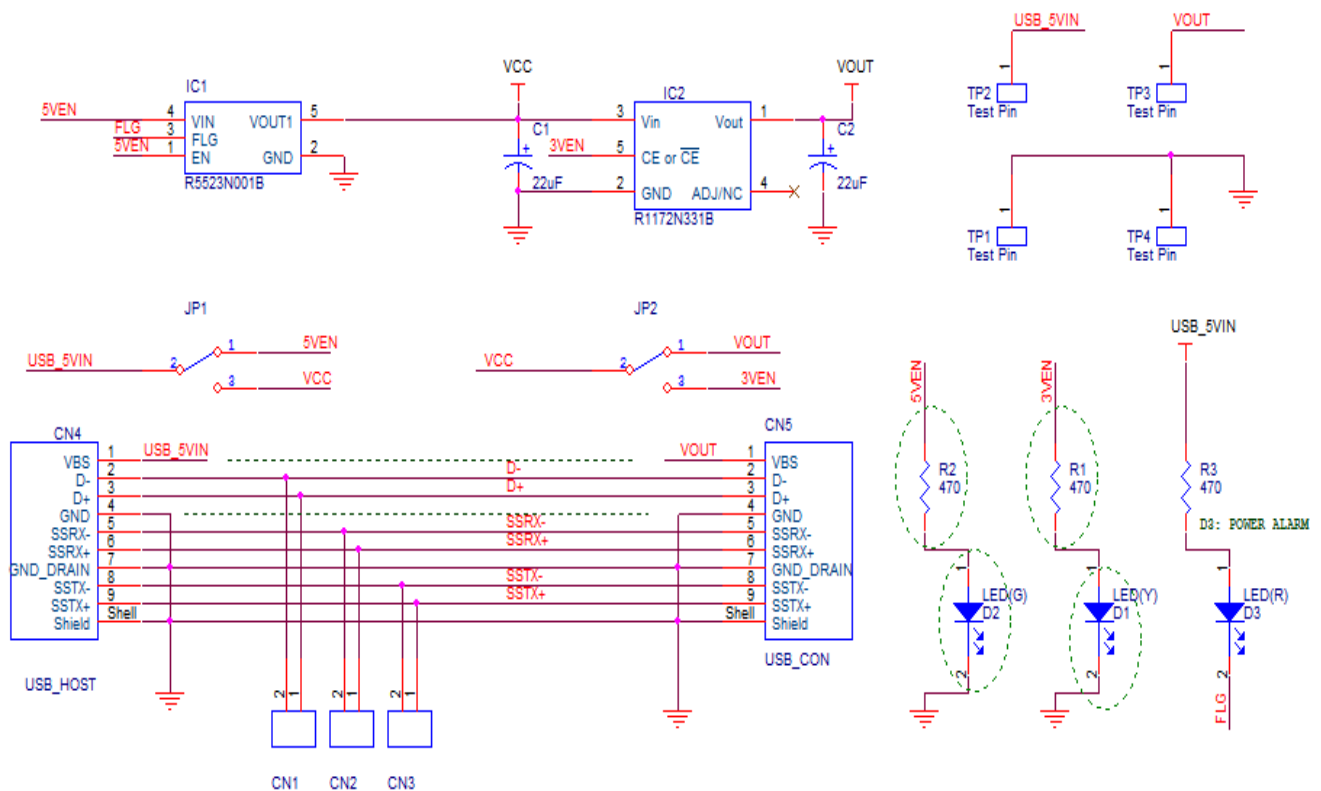

Figure-2 USB3.0 Fixture Board (back)

### 3.0 Function

- Test connector for all of signal and power pins
- LED indicates power status
- Over-current protection with power switch IC
- Alternative Output Voltage: 5v to 5v/3.3v
- Voltage can be tested conveniently and directly
- Current can be tested conveniently and directly
- External power supply support

### 4.0 Schematic profile



1. IC1 can work as short and over load protection. When external load current is larger than 500mA, or short output, it will perform protection function. Meanwhile, LED D3 (R) will show on for warning function.
2. IC2 is a voltage converter with 5V input and 3.3V output.
3. Three pairs of USB test points can test signal working status wholly.

## 5.0 Application note

### ● Different Voltage switch

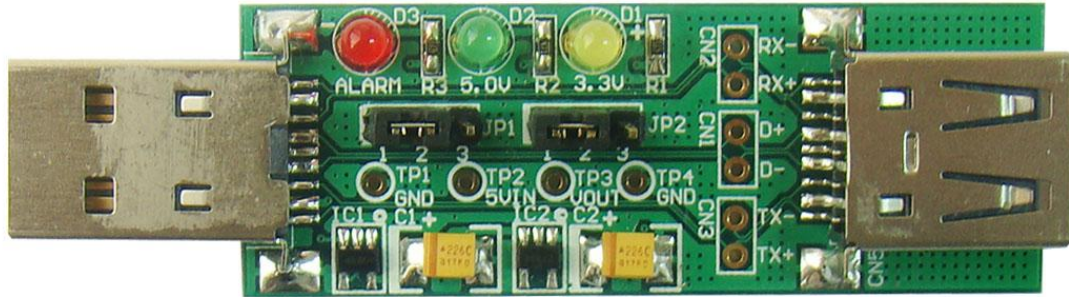

Set Jumper Cap on JP1 1-2 position, IC1 can work normally. Set Jumper Cap on JP2 1-2 position, IC2 cannot work. Meanwhile, LED D2 (G) will show on and output voltage shows 5V.

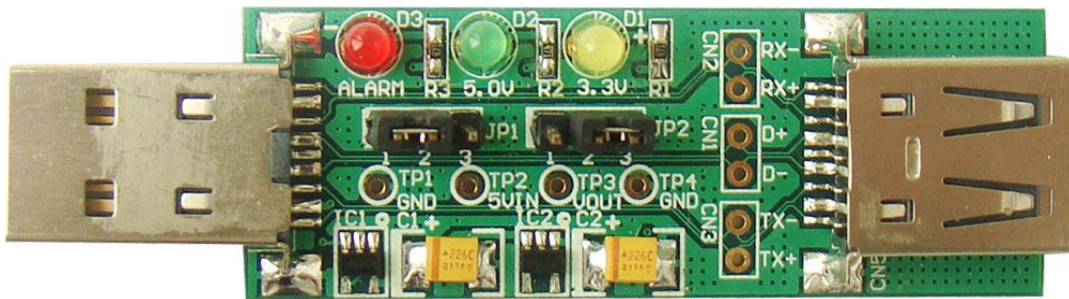

Set Jumper Cap on JP1 1-2 position, IC1 can work normally. Set Jumper Cap on JP2 2-3 position, IC2 can work normally. Meanwhile, LED D1 (Y) and LED D2 (G) will show on. Output voltage shows 3.3V.

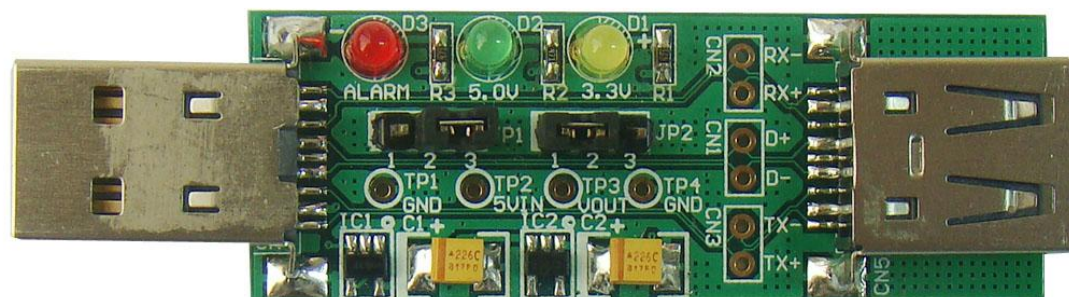

Set Jumper Cap on JP1 2-3 position, IC1 cannot work. Set Jumper Cap on JP2 1-2 position, IC2 cannot work. Meanwhile, output voltage shows 5V.

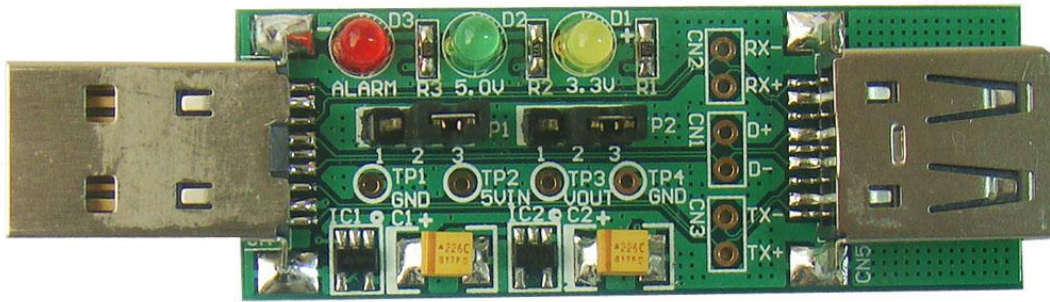

Set Jumper Cap on JP1 2-3 position, IC1 cannot work. Set Jumper Cap on JP2 2-3 position, IC2 can work normally. Meanwhile, output voltage shows 3.3v.

● Voltage test

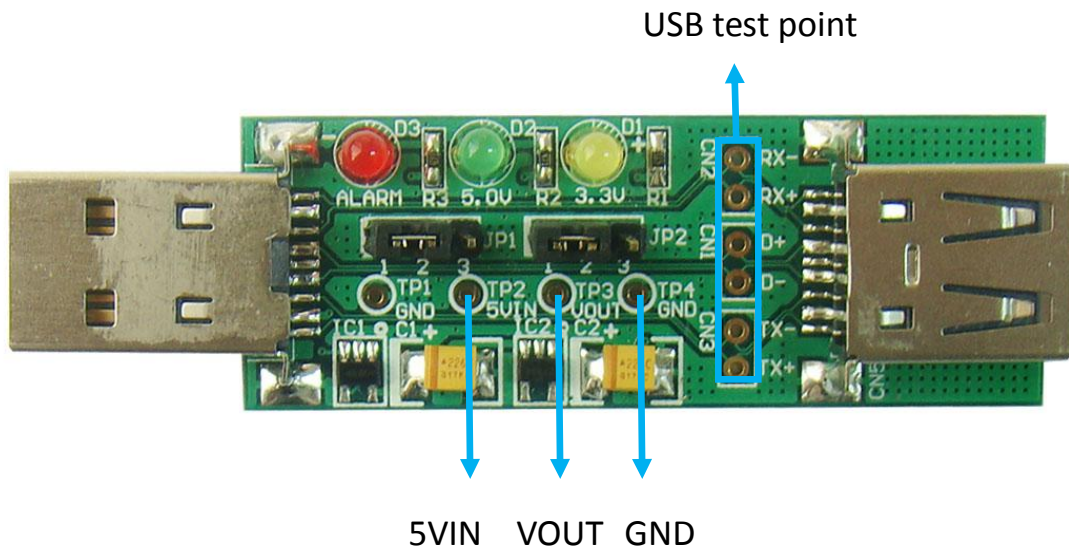

TP2 is a test point for input voltage 5V. TP3 is a test point for output voltage VOUT. Input voltage can be obtained by measuring TP2 and TP4 (TP1), and output voltage can be obtained by measuring TP3 and TP4 (TP1).

● **Current test**

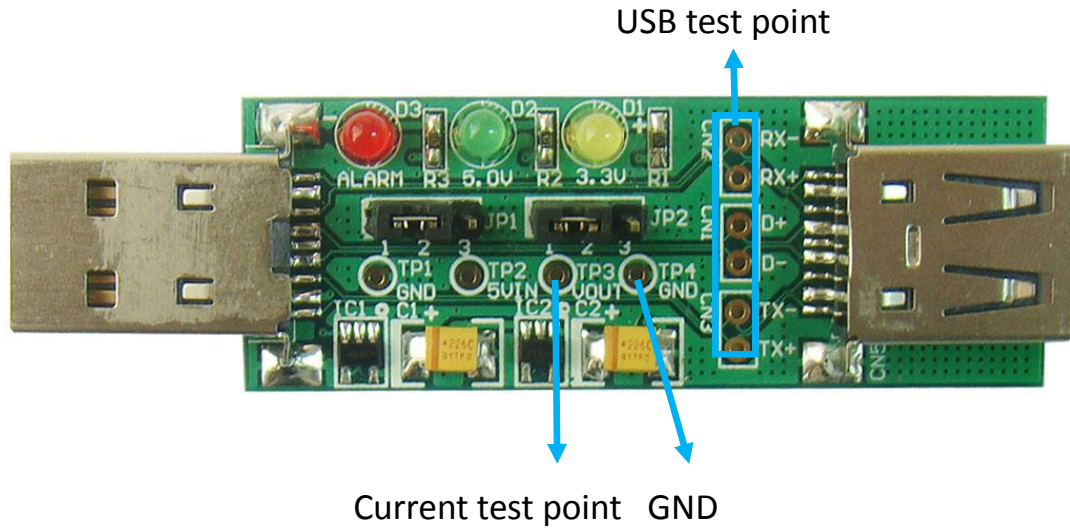

Current consumption of USB device can be obtained by measuring TP3 and TP4 (TP1) directly.

● **External power supply**

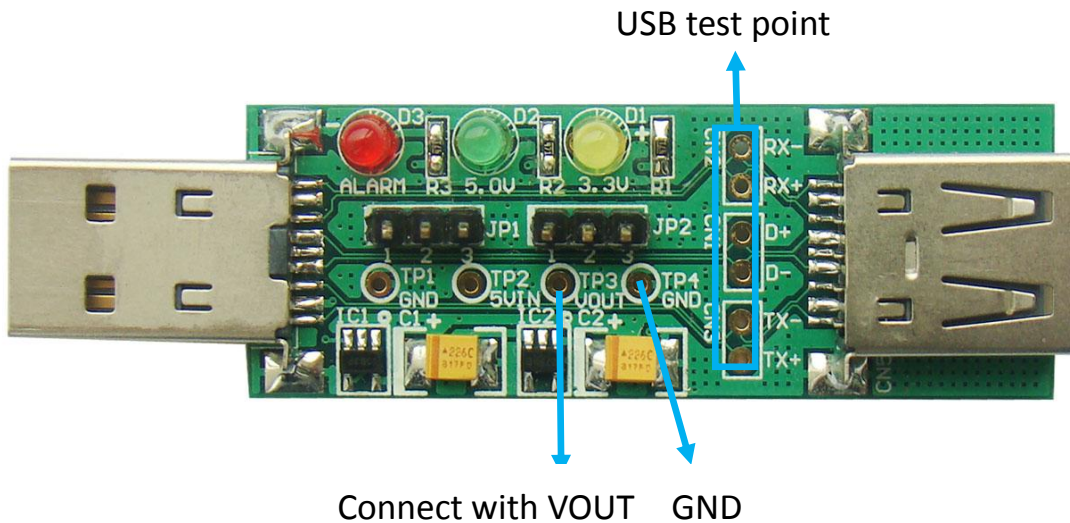

For USB special voltage supply need, the user can choose external power to replace USB power supply. Before using, the user must remove Jumper Cap on JP1 and JP2 position, and ensure TP3 connecting with VOUT, TP4 (TP1) with GND.

## 6.0 Caution

- All products specifications are subject to change without notice.
- Bplus Technology reserves the right to modify the products in its line during the course of the year.

## 7.0 Maintenance

There is no guarantee for incorrect operation.

Please contact the distributor for more details.