

Micro SD Extender

Reference Schematic Rev. 1.2

Schematic update note:

Second schematic.....2009/May/13 V1.2

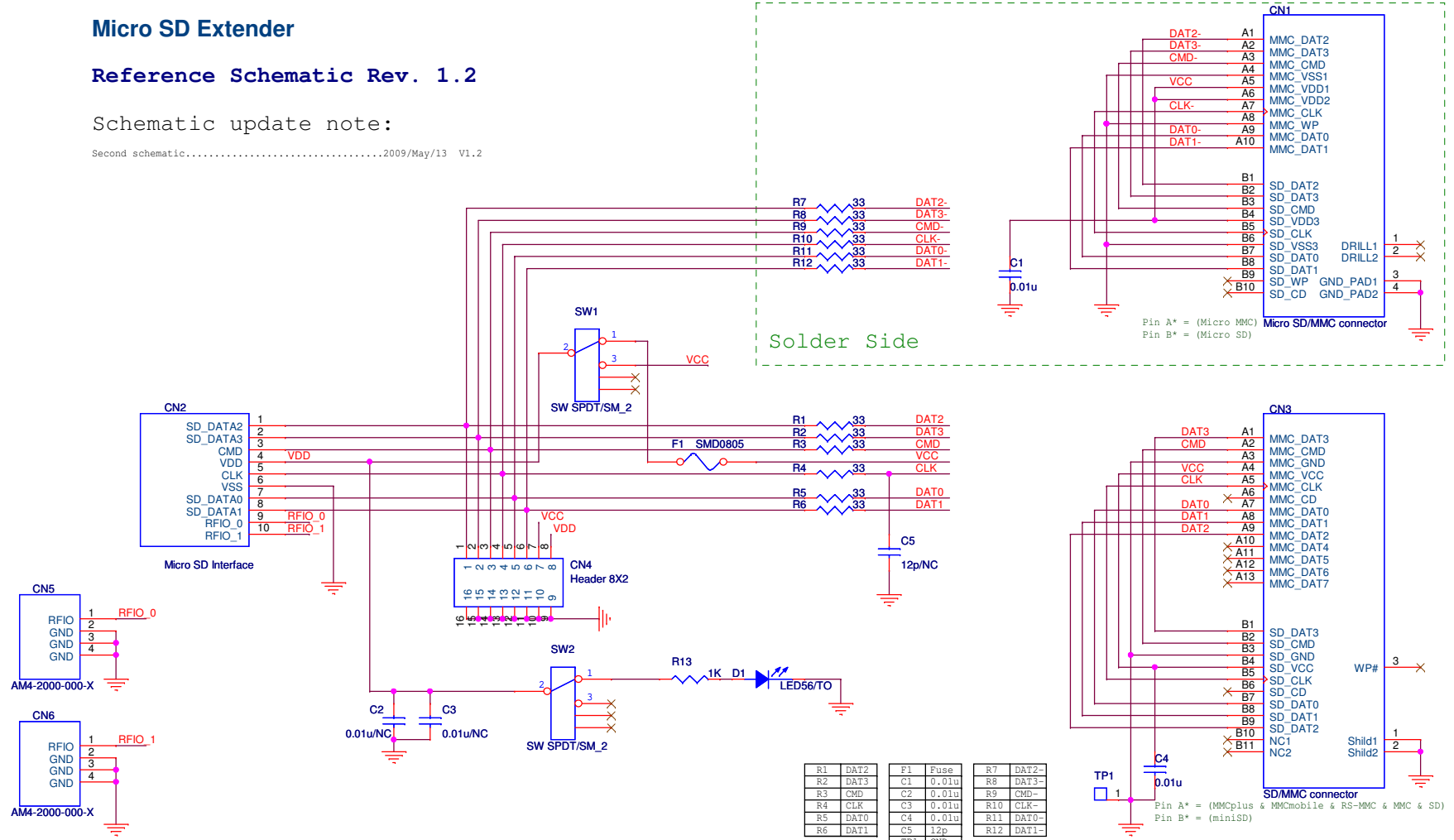

R1	DAT2	F1	Fuse	R7	DAT2-
R2	DAT3	C1	0.01u	R8	DAT3-
R3	CMD	C2	0.01u	R9	CMD-
R4	CLK	C3	0.01u	R10	CLK-
R5	DAT0	C4	0.01u	R11	DAT0-
R6	DAT1	C5	12p	R12	DAT1-
		TP1	GND		
		D1	LED		

SW1	Fuse
SW2	LED

PCB Layout Guideline

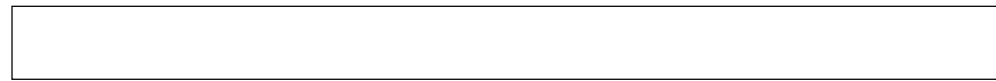

Title		Micro SD Extender		Designer: Gerry Chen	
Size	B	Document Number	Micro SD Extender	Bplus technology Co., Ltd.	Rev
					1.2
Date:	Wednesday, July 01, 2009	Sheet	1	of	1